

Backward Curved Centrifugal Fans

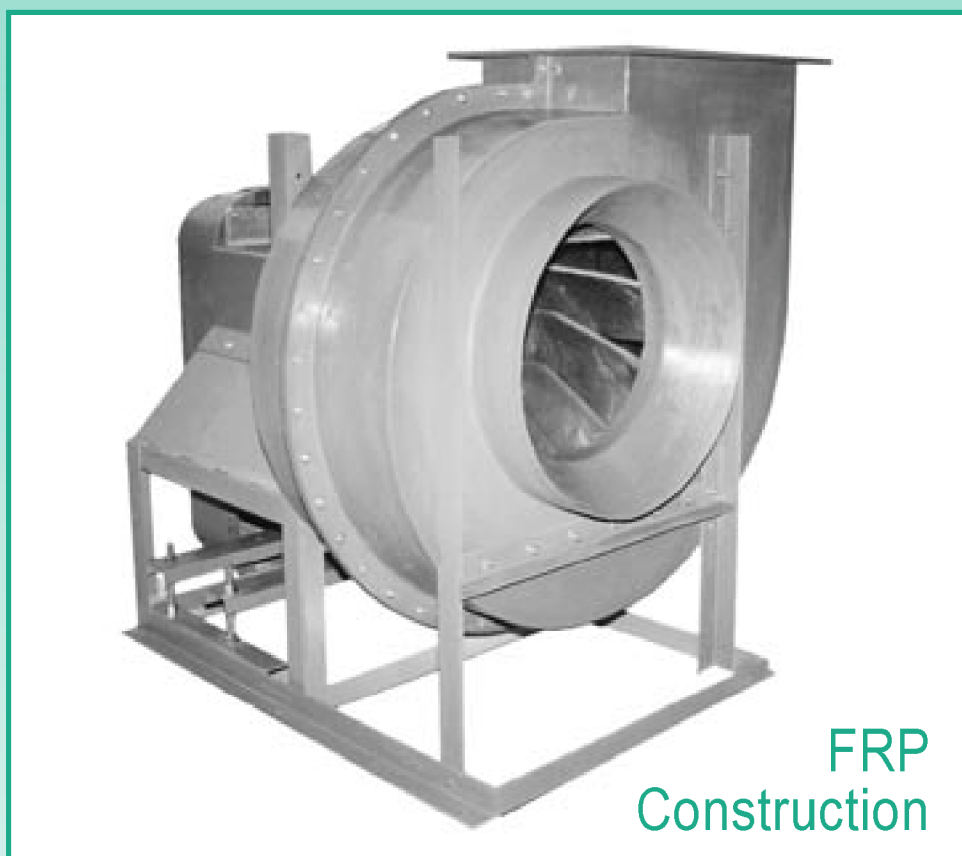

- Four Sizes
- Industrial and Commercial Applications
- Static pressures up to 14" W.G. (3477 Pa)
- Volume Range 400 CFM (189 l/sec) up to 5000 CFM (2360 l/sec)



Plasticair

Introduction

Plasticair's BCMPA Exhaust Fan Series has been specifically designed for exposure to gas streams containing corrosive fumes. The heavy duty backward curved impeller and robust housing offer favourable features such as corrosion resistant FRP construction for all gas contact parts, high efficiencies and quiet operation. Industries such as Electronics Manufacturing, Pulp and Paper and Chemical Manufacturing can benefit from this product as it provides rugged construction, and long life.

The BCMPA is available in four sizes and covers volume ranges of 400 CFM (189 l/sec) up to 5000 CFM (2360 l/sec), and the industrial heavy duty Class 2 construction allows for smooth operation up to 14" W.G. (3477 Pa).

Plasticair Inc. certifies that the BCMPA Series industrial Exhaust Fans shown herein are licensed to bear the AMCA Seal. The ratings shown are based on tests and procedures performed in accordance with AMCA Publication 211 and comply with the requirements of the AMCA Certified Ratings Program.



Standard Features

Housing Construction

This housing is available in a variety of CW and CCW rotations (page 10). The molded smooth surface provides an aerodynamic highly efficient passage for gas streams. Fabrication method is hand lay-up, and materials are vinyl ester resin and reinforcing glass.

Bearings are solid pillow block type rated for two hundred thousand hours.

Fasteners are a combination of 304/316 stainless steel.

Flanged outlets are supplied as standard not drilled.

Inlet connections are slip type, supplied as standard.

Shaft and Teflon Seal

This effective design has completely protected the

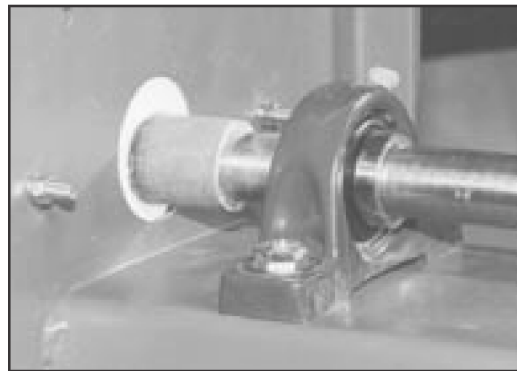

polished ground mild steel shaft from the corrosive gas stream. The shaft is encapsulated with a solid FRP shaft sleeve which pro-

trudes out from the teflon disk shaft seal located on the housing wall. The teflon seal and shaft sleeve are a machine fit for best possible reduction of leaking gas. 316 stainless steel shafts are available as an option.



Wheel Construction The BCMPA impeller is of a high efficiency non-overloading design. The backward curved wheel is constructed of solid vinyl ester resin and reinforcing glass. A sprocket and bushing are used for shaft attachment and are completely covered with a minimum 3/16" (5 mm) of FRP lay-up. All gas contact points are FRP complete with corrosion barrier. Plasticair's commitment to quality ensures that only hand lay-up methods are utilized for fabrication. This Class 2 impeller is comfortably rated to handle up to 14,000 feet per minute (71 m/sec) tip speed.



BCMPA Series Base 100 Option

Features

- Arrangement #10 only.
- Epoxy coated mild steel plates fastened together with 304 stainless steel bolts.
- Sizes 12 - 14 maximum motor size of 2 HP (1.5 KW).
- Sizes 16 - 18 maximum motor size of 7.5 HP (5.5 KW).
- Outdoor weather cover fabricated with UV stabilized FRP. For indoor applications, steel epoxy coated mesh guards are used. Both options fully protect motor, shaft and belts.
- The base 100 option is recommended for commercial applications.



BCMPA Series Base 200 Option

Features

- Arrangement #1, #9.
- Epoxy coated mild steel all welded construction.
- Size 12 - 14 maximum motor size 5 HP (4 KW).
- Size 16 - 18 maximum motor size 15 HP (11 KW).
- FRP drive and shaft guard. (Optional)
- This option is suited best for industrial applications.



BCMPA Series Base 300 Option

Features

- Arrangement #10, extra heavy duty construction for smooth operation up to the fan's maximum performance capacity.
- Epoxy coated mild steel all welded construction.
- FRP drive and shaft guards. (Optional)
- Motor maximum capacities are identical to the Base 200.
- This option is suited best for industrial applications.



BCMPA Series Base 400 Option

Features

- Arrangement #4.
- Epoxy coated mild steel all welded construction
- FRP Motor cover. (Optional)
- Motor maximum capacities are identical to Base 200.
- This option is best for applications that require direct drive arrangement #4 and are suited for commercial or industrial environments.

Accessories



Access Door: The bolt-on access door is designed to be flush with the inner surface of the fan housing. Therefore, flowing gas encounters minimal turbulence when passing the access door. The door is fastened to the fan housing with 304 stainless steel hardware and is sealed air tight with neoprene gasket (exotic gasket is available upon request). The fastening bolts are encapsulated with full thickness FRP to give maximum corrosion resistance protection.

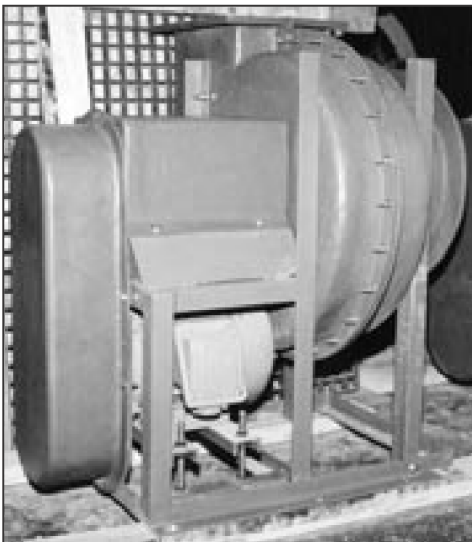

Backdraft Dampers: Gravity operated backdraft dampers can be supplied in FRP or PVC construction. Available in the up-blast and top horizontal discharge positions.

Outdoor Weather Guard: For outdoor installations Plasticair's FRP weather guard is designed for not only protecting the fan against outdoor elements but also serving as an OSHA rated belt and shaft guard.

Indoor Belt Guard: For indoor installations a steel mesh epoxy coated guard provides OSHA rated protection and is maintenance friendly.



Motor and V-belt drive sets as per customers requirements.

Flanged inlet: An FRP flange may be supplied for the inlet of the fan. The flange is laminated directly to the spigot of the scroll and is supplied as an option not drilled.



Accessories

Teflon Packed Seal: Stuffing box housing constructed from machined FRP. The mechanical shaft seal is spring loaded and lithium grease filled. This seal is very effective on system designs where fans contain harsh air systems and are located indoors.

Outlet Stacks: Fabricated in FRP or PVC and designed to suit customers requirements.

Outlet Stack Supports: Fans supporting stacks that weigh over 90 lbs will require an extra support located at the bottom of the scroll.

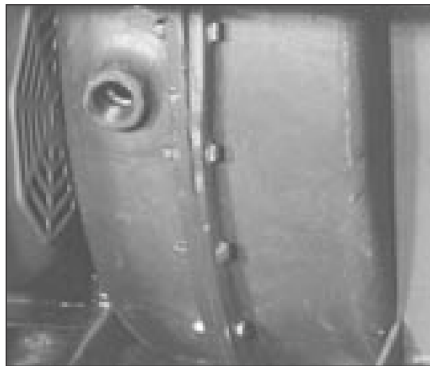

PVC Drains are laminated directly into the housing and located at the lowest point.

Solid FRP Drains: Plasticair's standard PVC drain can be upgraded to a solid FRP drain complete with plug and laminated into the lowest point of the fan scroll. The FRP drain

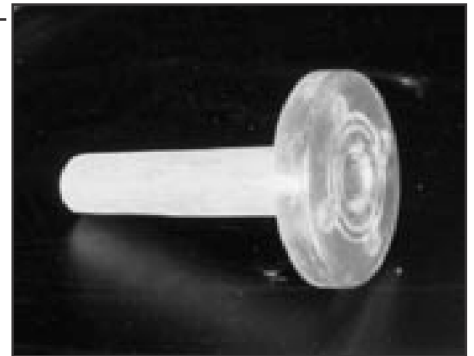

is flanged and drilled to standard pipe flange specification.

- PVC Flexible Connections
- Nexus lining
- Option for Polyester resin
- 304 or 316 stainless steel motor and bearing pedestals
- Split pillow block bearings
- Paint thickness to customer specification
- Vibration isolation



Statically grounded graphite lining for spark resistant construction

Option Explosion Proof Motors

All air stream parts are grounded to the motor grounding lug, therefore eliminating any opportunity for static charge to build up and spark.

Inlet Diameter: 12"
 Outlet Area: 0.538 sq/ft

Maximum Safe Speed Base 100: 2200 RPM · Maximum Safe Speed Base 200: 3600 RPM
 Maximum Safe Speed Base 300: 3600 RPM · Maximum Safe Speed Base 400: 3600 RPM

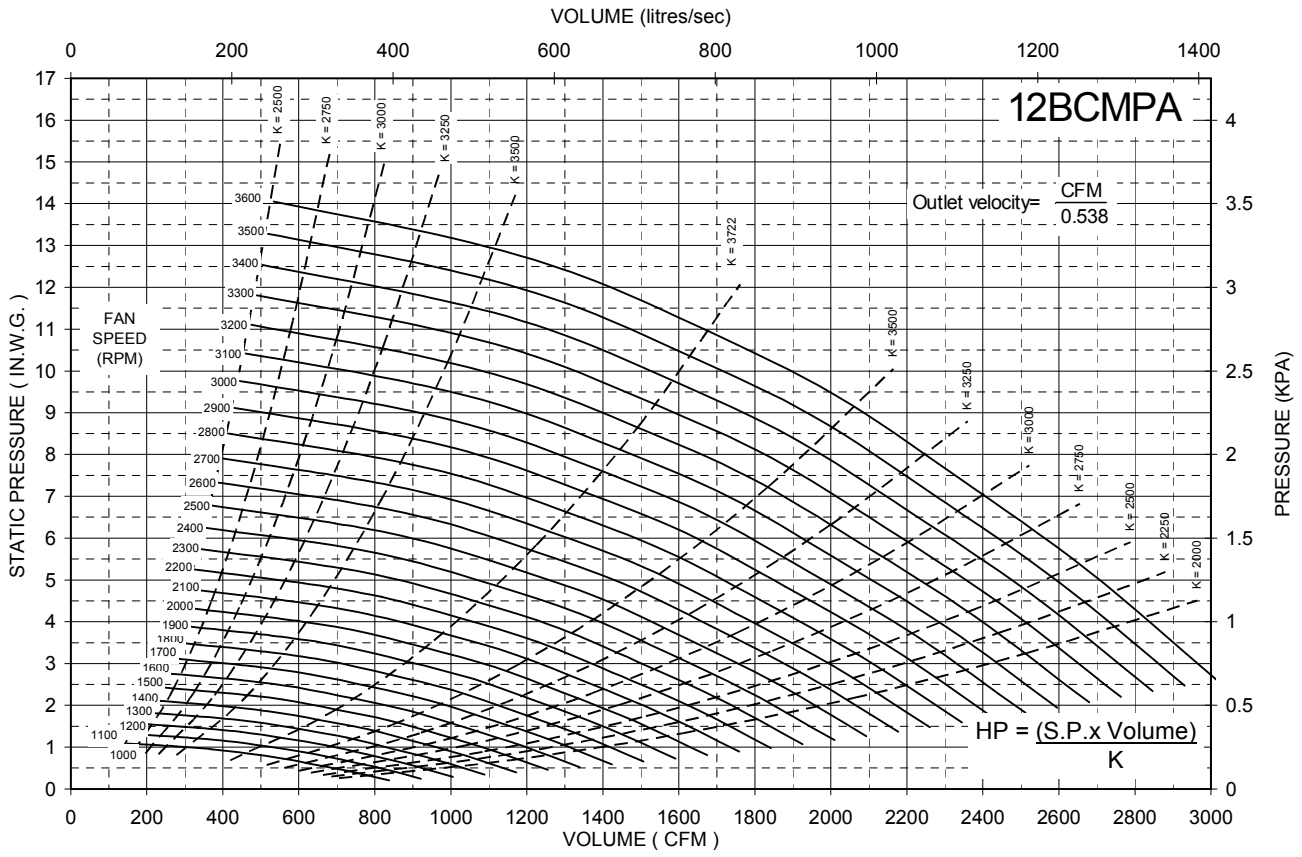

Inlet Diameter: 14"
 Outlet Area: 0.734 sq/ft

Maximum Safe Speed Base 100: 1800 RPM · Maximum Safe Speed Base 200: 3000 RPM
 Maximum Safe Speed Base 300: 3000 RPM · Maximum Safe Speed Base 400: 3000 RPM

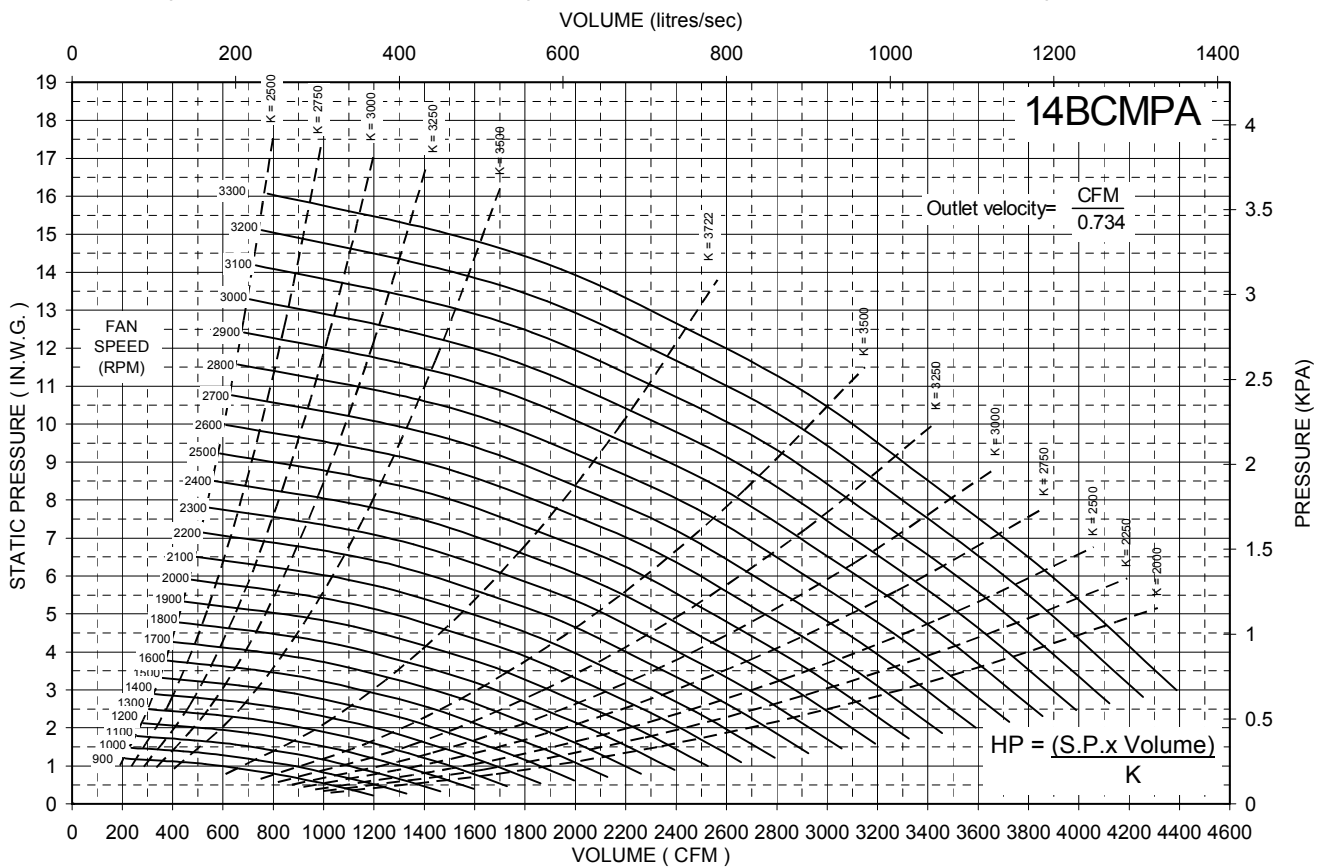

PERFORMANCE CERTIFIED IS FOR INSTALLATION TYPE B – FREE INLET, DUCTED OUTLET. POWER RATING (BHP) DOES NOT INCLUDE TRANSMISSION LOSSES. PERFORMANCE RATINGS DO NOT INCLUDE THE EFFECTS OF APPURTENANCES (ACCESSORIES).

Inlet Diameter: 16"
 Outlet Area: 0.96 sq/ft

Maximum Safe Speed Base 100: 1500 RPM · Maximum Safe Speed Base 200: 2600 RPM
 Maximum Safe Speed Base 300: 2600 RPM · Maximum Safe Speed Base 400: 2600 RPM

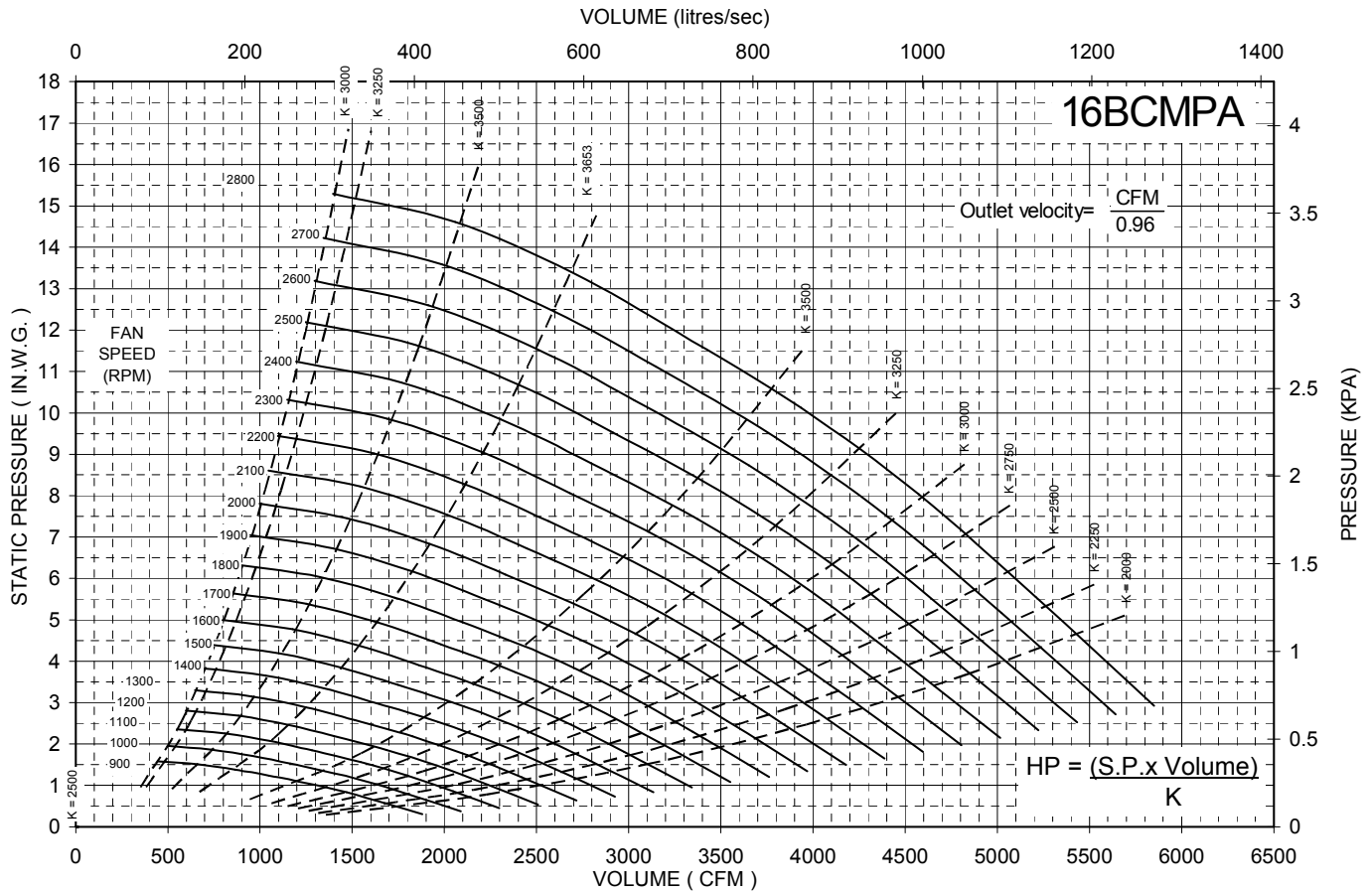

Inlet Diameter: 18"
 Outlet Area: 1.217 sq/ft

Maximum Safe Speed Base 100: 1300 RPM · Maximum Safe Speed Base 200: 2300 RPM
 Maximum Safe Speed Base 300: 2300 RPM · Maximum Safe Speed Base 400: 2300 RPM

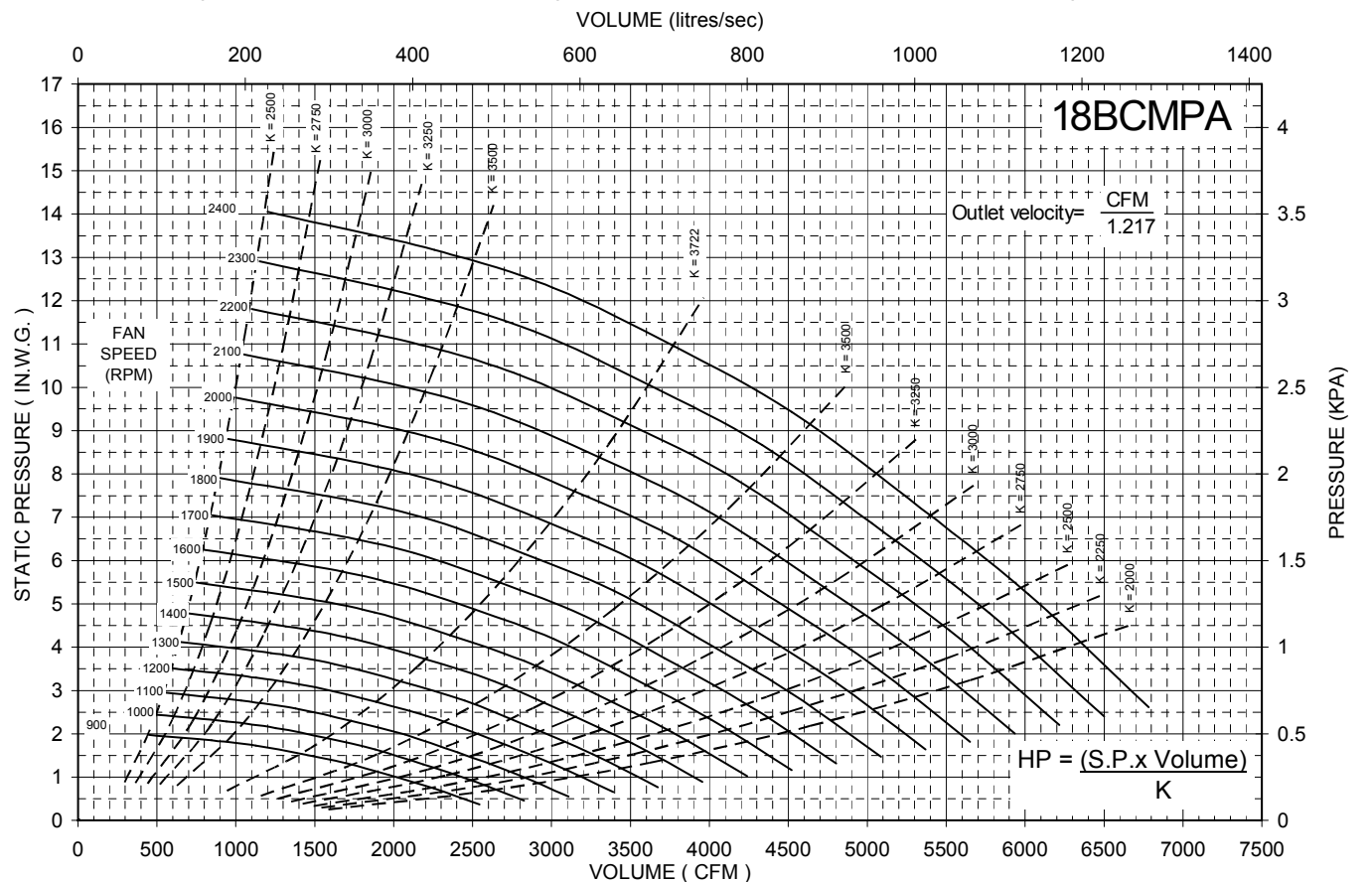

PERFORMANCE CERTIFIED IS FOR INSTALLATION TYPE B – FREE INLET, DUCTED OUTLET. POWER RATING (BHP) DOES NOT INCLUDE TRANSMISSION LOSSES. PERFORMANCE RATINGS DO NOT INCLUDE THE EFFECTS OF APPURTENANCES (ACCESSORIES).

BCMPA Series Base 100

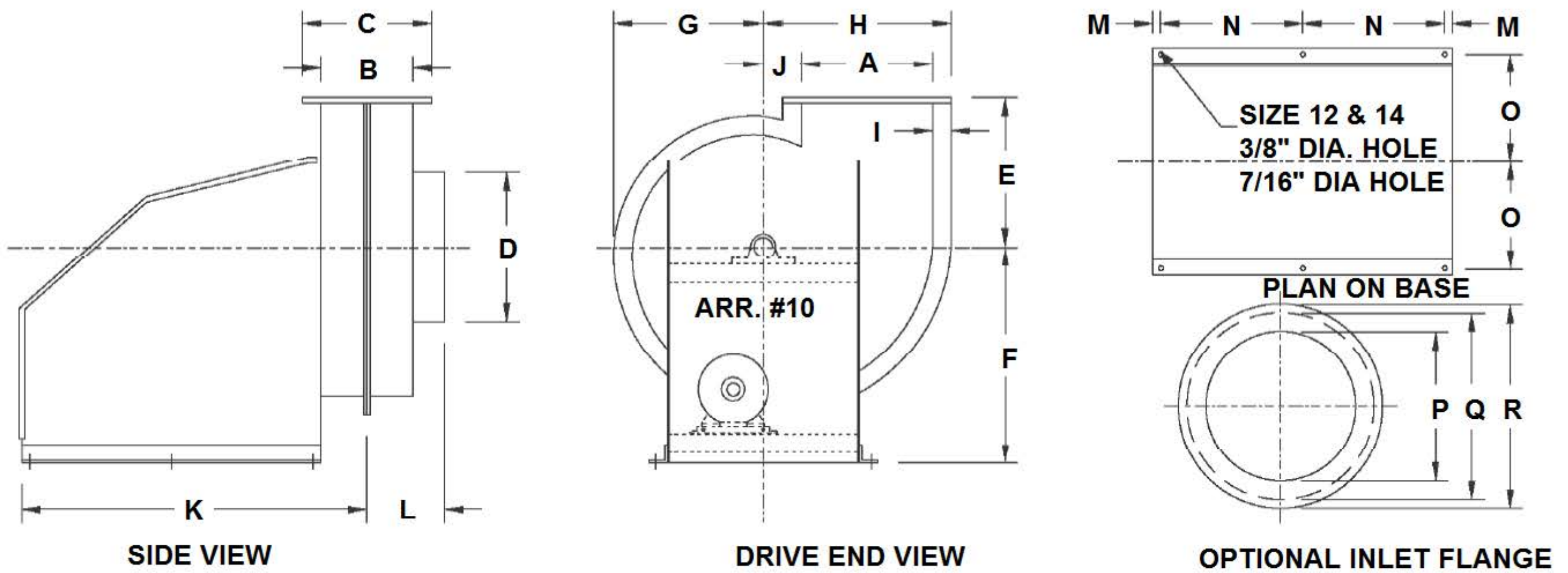

BCMPA DIMENSIONS – BASE 100: inches (mm)

FAN SIZE	A inside	B inside	C	D	E	F	G	H	I	J	K	L	M	N	O	INLET FLANGE DIMENSIONS				
																P	Q (BCD)	R min.	Flange thickness	No. & dia of holes
12	10 1/2 (267)	7 3/8 (187)	10 3/8 (264)	12 (305)	12 (305)	17 3/8 (441)	12 (305)	15 (381)	1 1/2 (38)	3 (76)	28 (711)	6 3/8 (162)	5/8 (16)	11 3/8 (289)	8 5/8 (219)	12 (305)	15 (381)	16 3/8 (416)	3/8 (10)	12 - 7/16 (11)
14	12 1/4 (311)	8 5/8 (219)	12 5/8 (321)	14 (356)	14 (356)	17 3/8 (441)	14 1/4 (362)	17 3/4 (451)	2 (51)	3 1/2 (89)	28 5/8 (727)	7 3/8 (187)	5/8 (16)	11 3/8 (289)	8 5/8 (219)	14 (356)	17 (432)	18 3/8 (467)	3/8 (10)	12 - 7/16 (11)
16	14 (356)	9 7/8 (251)	14 7/8 (378)	16 (406)	16 1/2 (419)	24 (610)	16 1/2 (419)	20 1/4 (514)	2 1/2 (64)	3 3/4 (95)	38 1/8 (968)	8 1/2 (216)	1 (25)	15 1/2 (394)	11 5/8 (295)	16 (406)	19 (483)	20 3/8 (518)	1/2 (13)	16 - 7/16 (11)
18	15 3/4 (400)	11 1/8 (283)	16 1/8 (410)	18 (457)	18 1/2 (470)	24 (610)	18 3/8 (467)	22 3/8 (568)	2 1/2 (64)	4 1/8 (105)	38 3/4 (984)	9 1/2 (241)	1 (25)	15 1/2 (394)	11 5/8 (295)	18 (457)	21 (533)	22 3/8 (568)	1/2 (13)	16 - 7/16 (11)

Note: Add 3" (76 mm) to L dimension for optional inlet flange.

BCMPA Series Base 200

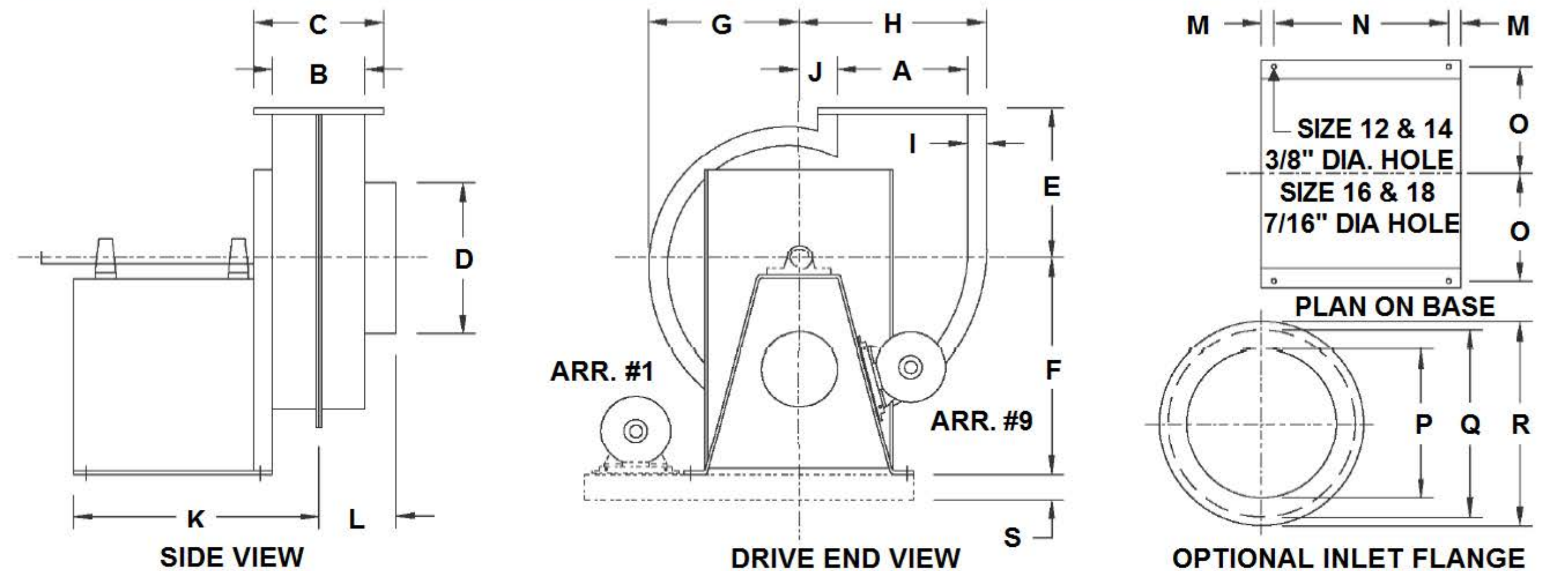

BCMPA DIMENSIONS – BASE 200: inches (mm)

FAN SIZE	A inside	B inside	C	D	E	F	G	H	I	J	K	L	M	N	O	INLET FLANGE DIMENSIONS					S Arr. 1
																P	Q (BCD)	R min.	Flange thickness	No. & dia of holes	
12	10 1/2 (267)	7 3/8 (187)	10 3/8 (264)	12 (305)	12 (305)	17 3/8 (441)	12 (305)	15 (381)	1 1/2 (38)	3 (76)	20 (508)	6 3/8 (162)	1 (25)	14 (356)	8 5/8 (219)	12 (305)	15 (381)	16 3/8 (416)	1/2 (13)	12 - 7/16 (11)	2 (51)
14	12 1/4 (311)	8 5/8 (219)	12 5/8 (321)	14 (356)	14 (356)	17 3/8 (441)	14 1/4 (362)	17 3/4 (451)	2 (51)	3 1/2 (89)	20 5/8 (524)	7 3/8 (187)	1 (25)	14 (356)	8 5/8 (219)	14 (356)	17 (432)	18 3/8 (467)	1/2 (13)	12 - 7/16 (11)	2 (51)
16	14 (356)	9 7/8 (251)	14 7/8 (378)	16 (406)	16 1/2 (419)	24 (610)	16 1/2 (419)	20 1/4 (514)	2 1/2 (64)	3 3/4 (95)	25 1/4 (641)	8 1/2 (216)	1 1/4 (32)	17 1/2 (445)	10 3/8 (264)	16 (406)	19 (483)	20 3/8 (518)	1/2 (13)	16 - 7/16 (11)	2 (51)
18	15 3/4 (400)	11 1/8 (283)	16 1/8 (410)	18 (457)	18 1/2 (470)	24 (610)	18 3/8 (467)	22 3/8 (568)	2 1/2 (64)	4 1/8 (105)	25 7/8 (657)	9 1/2 (241)	1 1/4 (32)	17 1/2 (445)	10 3/8 (264)	18 (457)	21 (533)	22 3/8 (568)	1/2 (13)	16 - 7/16 (11)	2 (51)

Note: Add 3" (76 mm) to L dimension for optional inlet flange. Dimension S for optional arrangement 1 only.

BCMPA Series Base 300

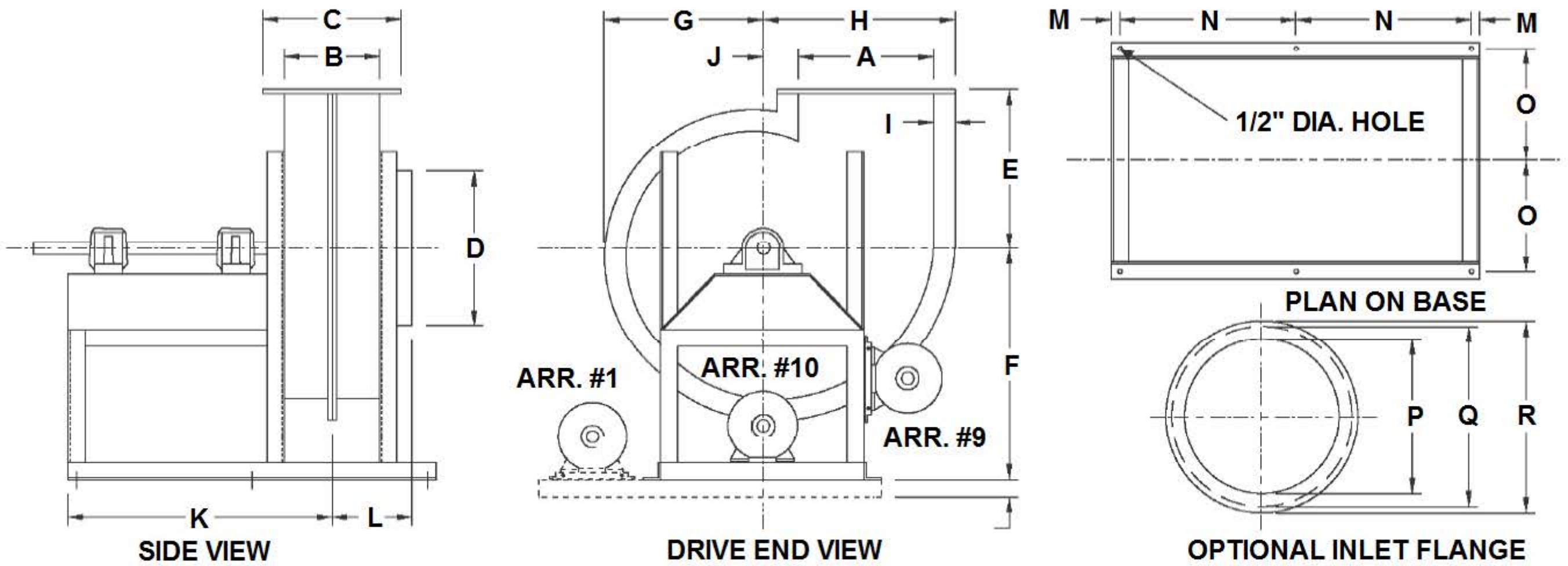

BCMPA DIMENSIONS – BASE 300: inches (mm)

FAN SIZE	A inside	B inside	C	D	E	F	G	H	I	J	K	L	M	N	O	INLET FLANGE DIMENSIONS					S Arr. 1
																P	Q (BCD)	R min.	Flange thickness	No. & dia of holes	
12	10 1/2 (267)	7 3/8 (187)	10 3/8 (264)	12 (305)	12 (305)	22 (559)	12 (305)	15 (381)	1 1/2 (38)	3 (76)	23 5/8 (600)	6 3/8 (162)	1 3/8 (35)	14 3/4 (375)	9 1/4 (235)	12 (305)	15 (381)	16 3/8 (416)	1/2 (13)	12 - 7/16 (11)	2 (51)
14	12 1/4 (311)	8 5/8 (219)	12 5/8 (321)	14 (356)	14 (356)	23 (584)	14 1/4 (362)	17 3/4 (451)	2 (51)	3 1/2 (89)	24 1/2 (622)	7 3/8 (187)	1 (25)	16 (406)	10 1/4 (260)	14 (356)	17 (432)	18 3/8 (467)	1/2 (13)	12 - 7/16 (11)	2 (51)
16	14 (356)	9 7/8 (251)	14 7/8 (378)	16 (406)	16 1/2 (419)	24 (610)	16 1/2 (419)	20 1/4 (514)	2 1/2 (64)	3 3/4 (95)	28 3/8 (721)	8 1/2 (216)	1 (25)	18 5/8 (473)	12 (305)	16 (406)	19 (483)	20 3/8 (518)	1/2 (13)	16 - 7/16 (11)	2 (51)
18	15 3/4 (400)	11 1/8 (283)	16 1/8 (410)	18 (457)	18 1/2 (470)	27 (686)	18 3/8 (467)	22 3/8 (568)	2 1/2 (64)	4 1/8 (105)	31 (787)	9 1/2 (241)	1 (25)	20 1/2 (521)	13 (330)	18 (457)	21 (533)	22 3/8 (568)	1/2 (13)	16 - 7/16 (11)	2 (51)

Note: Add 3" (76 mm) to L dimension for optional inlet flange. Dimension S for optional arrangement 1 only.

BCMPA Series Base 400

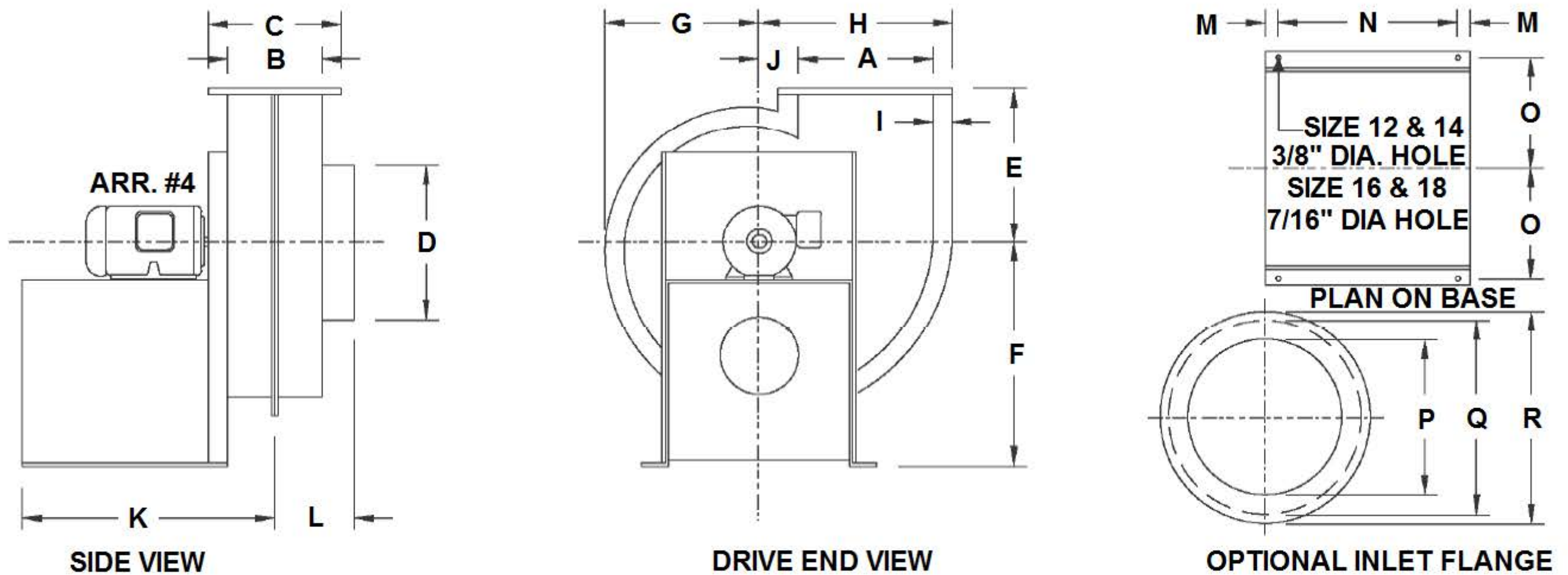

BCMPA DIMENSIONS – BASE 400: inches (mm)

FAN SIZE	A inside	B inside	C	D	E	F	G	H	I	J	K	L	M	N	O	INLET FLANGE DIMENSIONS				
																P	Q (BCD)	R min.	Flange thickness	No. & dia of holes
12	10 1/2 (267)	7 3/8 (187)	10 3/8 (264)	12 (305)	12 (305)	17 3/8 (441)	12 (305)	15 (381)	1 1/2 (38)	3 (76)	20 (508)	6 3/8 (162)	1 (25)	14 (356)	8 5/8 (219)	12 (305)	15 (381)	16 3/8 (416)	1/2 (13)	12 - 7/16 (11)
14	12 1/4 (311)	8 5/8 (219)	12 5/8 (321)	14 (356)	14 (356)	17 3/8 (441)	14 1/4 (362)	17 3/4 (451)	2 (51)	3 1/2 (89)	20 5/8 (524)	7 3/8 (187)	1 (25)	14 (356)	8 5/8 (219)	14 (356)	17 (432)	18 3/8 (467)	1/2 (13)	12 - 7/16 (11)
16	14 (356)	9 7/8 (251)	14 7/8 (378)	16 (406)	16 1/2 (419)	24 (610)	16 1/2 (419)	20 1/4 (514)	2 1/2 (64)	3 3/4 (95)	25 1/4 (641)	8 1/2 (216)	1 1/4 (32)	17 1/2 (445)	10 3/8 (264)	16 (406)	19 (483)	20 3/8 (518)	1/2 (13)	16 - 7/16 (11)
18	15 3/4 (400)	11 1/8 (283)	16 1/8 (410)	18 (457)	18 1/2 (470)	24 (610)	18 3/8 (467)	22 3/8 (568)	2 1/2 (64)	4 1/8 (105)	25 7/8 (657)	9 1/2 (241)	1 1/4 (32)	17 1/2 (445)	10 3/8 (264)	18 (457)	21 (533)	22 3/8 (568)	1/2 (13)	16 - 7/16 (11)

Note: Add 3" (76 mm) to L dimension for optional inlet flange.

Rotational Discharge Dimensions

BCMPA DIMENSIONS FOR VARIOUS ROTATIONS: inches (mm)

FAN SIZE	12					14				
	ROTATION	A	B	C	D - BASE 100, 200, 400	D - BASE 300	A	B	C	D - BASE 100, 200, 400
CW45	14 1/4 (362)	11 1/4 (286)	19 1/8 (486)	17 3/8 (441)	22 (559)	16 7/8 (429)	13 3/8 (340)	22 1/2 (572)	17 3/8 (441)	23 (584)
CW90	13 1/2 (343)	12 (305)	15 (381)	17 3/8 (441)	22 (559)	16 (406)	14 (356)	17 3/4 (451)	17 3/8 (441)	23 (584)
CW135	12 3/4 (324)	19 1/8 (486)	14 1/4 (362)	17 3/8 (441)	22 (559)	15 1/8 (384)	22 1/2 (572)	16 7/8 (429)	17 3/8 (441)	23 (584)
CW270	12 (305)	13 1/2 (343)	12 (305)	17 3/8 (441)	22 (559)	14 (356)	16 (406)	14 1/4 (362)	18 3/8 * (467)	23 (584)
CW315	19 1/8 (486)	12 3/4 (324)	11 1/4 (286)	17 3/8 (441)	22 (559)	22 1/2 (572)	15 1/8 (384)	13 3/8 (340)	17 3/8 (441)	23 (584)
CCW45	11 1/4 (286)	14 1/4 (362)	19 1/8 (486)	17 3/8 (441)	22 (559)	13 3/8 (340)	16 7/8 (429)	22 1/2 (572)	17 3/8 (441)	23 (584)
CCW90	12 (305)	13 1/2 (343)	15 (381)	17 3/8 (441)	22 (559)	14 (356)	16 (406)	17 3/4 (451)	17 3/8 (441)	23 (584)
CCW135	19 1/8 (486)	12 3/4 (324)	14 1/4 (362)	17 3/8 (441)	22 (559)	22 1/2 (572)	15 1/8 (384)	16 7/8 (429)	17 3/8 (441)	23 (584)
CCW270	13 1/2 (343)	12 (305)	12 (305)	17 3/8 (441)	22 (559)	16 (406)	14 (356)	14 1/4 (362)	18 3/8 * (467)	23 (584)
CCW315	12 3/4 (324)	19 1/8 (486)	11 1/4 (286)	17 3/8 (441)	22 (559)	15 1/8 (384)	22 1/2 (572)	13 3/8 (340)	17 3/8 (441)	23 (584)

* No clearance from bottom of fan case to ground on this rotation.

BCMPA DIMENSIONS FOR VARIOUS ROTATIONS: inches (mm)

FAN SIZE	16					18				
	ROTATION	A	B	C	D - BASE 100, 200, 400	D - BASE 300	A	B	C	D - BASE 100, 200, 400
CW45	17 3/8 (441)	13 7/8 (352)	22 7/8 (581)	24 (610)	24 (610)	21 1/4 (540)	17 1/4 (438)	29 (737)	24 (610)	27 (686)
CW90	16 1/2 (419)	14 (356)	18 1/4 (464)	24 (610)	24 (610)	20 1/8 (511)	18 1/2 (470)	22 3/8 (568)	24 (610)	27 (686)
CW135	15 5/8 (397)	22 7/8 (581)	17 3/8 (441)	24 (610)	24 (610)	19 (483)	29 (737)	21 1/4 (540)	24 (610)	27 (686)
CW270	14 (356)	16 1/2 (419)	14 3/4 (375)	24 (610)	24 (610)	18 1/2 (470)	20 1/8 (511)	18 3/8 (467)	24 (610)	27 (686)
CW315	22 7/8 (581)	15 5/8 (397)	13 7/8 (352)	24 (610)	24 (610)	29 (737)	19 (483)	17 1/4 (438)	24 (610)	27 (686)
CCW45	13 7/8 (352)	17 3/8 (441)	22 7/8 (581)	24 (610)	24 (610)	17 1/4 (438)	21 1/4 (540)	29 (737)	24 (610)	27 (686)
CCW90	14 (356)	16 1/2 (419)	18 1/4 (464)	24 (610)	24 (610)	18 1/2 (470)	20 1/8 (511)	22 3/8 (568)	24 (610)	27 (686)
CCW135	22 7/8 (581)	15 5/8 (397)	17 3/8 (441)	24 (610)	24 (610)	29 (737)	19 (483)	21 1/4 (540)	24 (610)	27 (686)
CCW270	16 1/2 (419)	14 (356)	14 3/4 (375)	24 (610)	24 (610)	20 1/8 (511)	18 1/2 (470)	18 3/8 (467)	24 (610)	27 (686)
CCW315	15 5/8 (397)	22 7/8 (581)	13 7/8 (352)	24 (610)	24 (610)	19 (483)	29 (737)	17 1/4 (438)	24 (610)	27 (686)

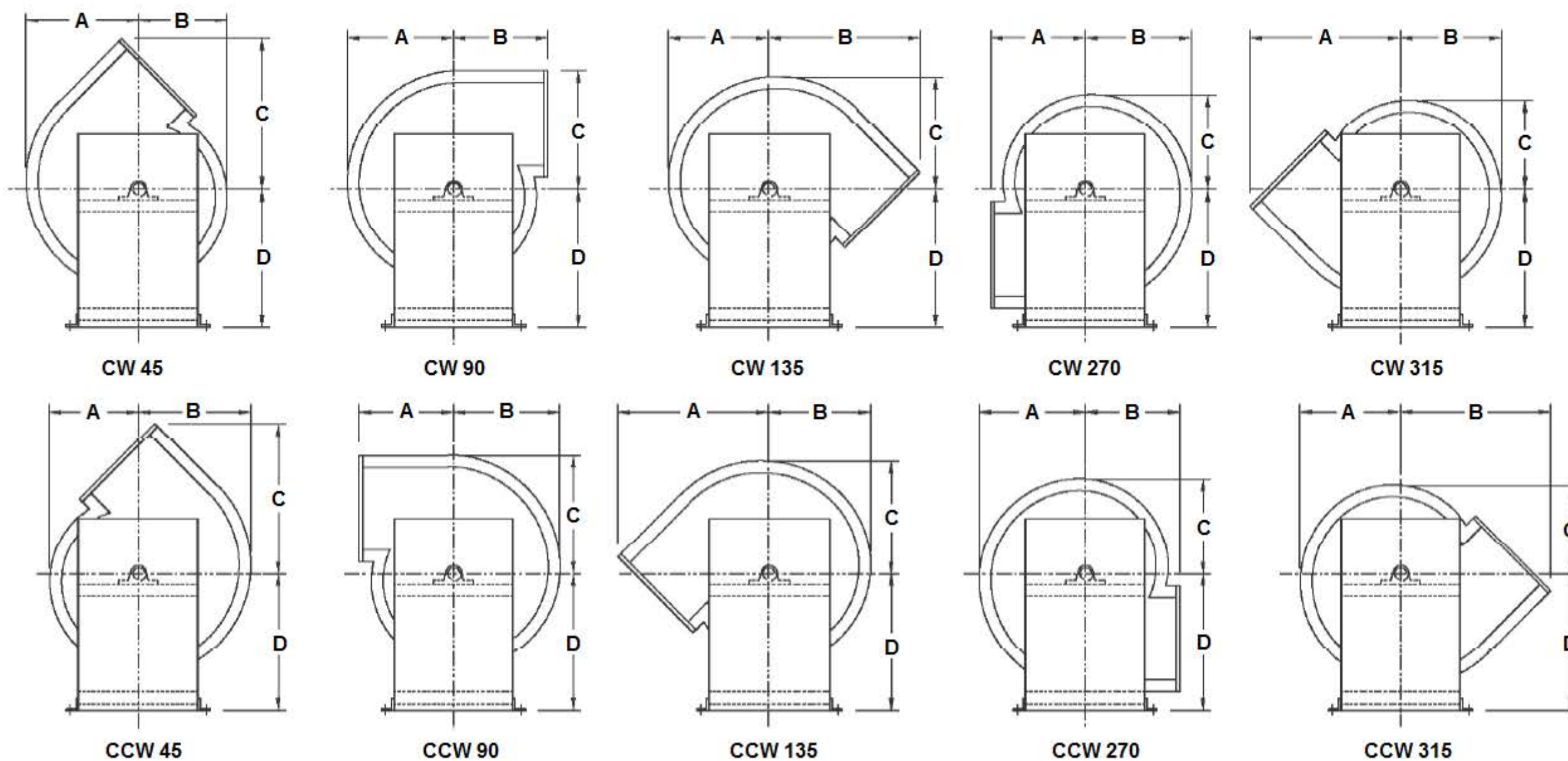

How To Specify Plasticair Backward Curved Fans – BCMPA Series

General

The fan is to be designed and constructed so that the corrosive gas stream only contacts solid FRP surfaces. All steel fasteners within the corrosive gas contact area will be stainless steel and encapsulated with a minimum of 0.1875" (5 mm) of FRP lay-up. The manufacturer must supply fans with RPM's equal or less than that shown in the fan schedule. The Acceptable AMCA arrangements are 1, 4, 9 and 10. Under no circumstances shall an impeller or motor shaft be exposed to the corrosive gas stream. All shafts will be fully protected with FRP shaft sleeves. The fan shall be constructed as per AMCA Standards 99.

Air Performance

The performance ratings will be in accordance with AMCA standard 210, and the fans must bear the AMCA Air Performance Seal.

Sound Data

Submitted sound data will be in accordance with AMCA standards 300 and 301. All submitted data will be in decibels, and presented in eight octave bands (10_12 watts). The designing engineer will perform the final dBA calculations.

Impeller Construction

The impeller is to be of a high efficiency backward curved design. The material of construction is to be vinyl ester resin (premium quality Hetron 922) and reinforcing glass throughout. The method of construction is to be hand lay-up only. Injection molded, cast molded or press molded techniques are not acceptable. The entire surface of the impeller exposed to the gas stream will be complete with a corrosion resin rich barrier consisting of C-veil and a smooth finish. The shaft is to be attached to the back-plate of the impeller by way of a taperlock bushing and a one piece cast sprocket hub. Sprockets with welded hubs are not acceptable. The entire shaft attachment assembly is to be completely covered with a minimum 0.25" (7 mm) of FRP lay-up. The impeller is to have a safe maximum tip speed rating of 13,500 feet per minute. Steel or thermoplastic impellers with FRP coatings are not acceptable.

Housing Construction

The fan housing is to be designed and constructed to resist vibration for static pressures up to 14" W.G. The material of construction will be vinyl ester resin (premium quality Hetron 922) and reinforcing glass throughout. The method of construction will be hand lay-up only. Injection molded and press molded techniques are not acceptable. The hand lay-up procedure will be as per ASTM standard C-582. The entire surface exposed to the corrosive gas stream will be complete with a corrosion resin rich barrier consisting of C-veil and a smooth finish. The outer surface of the housing will be a heavy gel coat, UV stabilized coating. The fan housing is to be of a bolted centre split design complete with neoprene gasket for easy impeller access. The outlet and centre split flanges are to be of heavy industrial quality. All Flanges are to have factory flat finishes. The inlet is to be slip connection type. The housing shall consist of a machined Teflon seal to limit gas leakage. Steel and thermoplastic housings complete with or without FRP linings are not acceptable.

Steel Fan Base (Base 100)

The fan base is to be constructed with heavy gauge steel to minimize vibration and to ensure long life. The fabrication method for all parts is to be precision forming and shearing. Prior to assembly, all parts are to be epoxy coated to a minimum thickness of 2-3 mils. The base is to be assembled using stainless steel fasteners.

Steel Fan Base (Base 200, 300, 400)

The fan base is to be of heavy-duty industrial quality to minimize vibration and to ensure long life. The bearing shaft pedestal is to be constructed of heavy gauge steel. The fabrication method is to be all welded. If a unitary motor mounting base (arrangement 1) is required, the bearing and shaft pedestal is to be attached by stitch welding. Attachment by nuts and bolts is not acceptable. After welding is complete, prior to the fan assembly, the fan base is to be coated with 2-4 mils of the manufacturers standard epoxy.

Bearings

Bearings are to be solid pillow block, self-aligning type. The bearings are to be rated and designed for a minimum L-10 life of 50,000 hours or L-50 life of 200,000 hours. The bearings are to be located out of the air stream and are to be covered with an easily removable guard for maintenance access. The method of lubrication will be grease.

Shaft

Fan shaft will be carbon steel 1045. The diameter of the shaft shall not be less than the specified manufacturer. The drive side of the shaft shall be countersunk for tachometer readings and complete with the correct keyways to accept V-belt drive selections. The impeller side of the shaft shall be complete with an FRP shaft sleeve which is bonded to the back-plate of the impeller and protrudes past the teflon shaft seal located on the housing.

Balancing And Testing

The balancing shall be in accordance with ASTM D-4167. The fan shall be test run and not shipped until vibration readings are within acceptable limits.

Warranty

The supplier shall warrant that all fan components shall be free from defects in materials and workmanship for a period of 15 months from date shipped or 12 months from equipment start up, whichever occurs first.

Plasticair Inc., Servicing Industry



FRP Fans



Scrubbing Equipment



Laboratory Fumehoods

Plasticair Product List

Scrubbers:

Horizontal Packed Bed - Single/Double (HS-Series)
Vertical Packed Bed Towers (VS-Series)
Odour Control Scrubbers (HCS, VCS-Series)
Demisters - Vane Type (P-Series)
Demisters - Mesh Type (M-Series)
Demisters - Multiple Stage Type (E-Series)
Venturi Scrubbers (ECE-Series)
Laboratory Fume Hood Scrubbers (FHS-Series)

Scrubber Applications:

Oil/Air Separators
Chlorine Scrubbers
Micro Chip Manufacturing Scrubbers
Plating Plant Scrubbers
Pickling Line Scrubbers
Chromic Acid Scrubbers And Demisters

FRP Fans:

Axial Fans - Vane / Tube
Panel Fans - Wall Mount / Box Mount
Inline Centrifugal - Backward Curved
Laboratory Fans - B.I. Utility Sets / B.I. Tubular
High Pressure Fans - Radial Blade
Medium Pressure Fans - Radial Blade
Medium Pressure Fans - Backward Curved
Mini Industrial Vent Sets - Radial Blade / B.I.

Plasticair's Sales Forces are located in major cities around the world.



Contact the factory for the agent closest to you.

Your Local Plasticair Representative is:

Bulletin #057
January 2008



Plasticair Inc.
1275 CRESTLAWN DRIVE,
MISSISSAUGA, ONTARIO, CANADA L4W 1A9
TEL: (905) 625-9164 FAX: (905) 625-0147

Plasticair Inc.
12555 SW FIRST STREET,
BEAVERTON, OREGON, USA 97005
TEL: (503) 672-7086 FAX: (503) 672-9852

email: sales@plasticair.com • Web Page: www.plasticair.com